

> We Are DEVELON

DEVELON is powered by 88 years of trusted engineering expertise and proven quality.

We transform this legacy into smart products and digital solutions that move the industry forward. Built on trust and driven by innovation, DEVELON remains dedicated to maximizing customer value in the future.

Powered by **Innovation**



<https://global.develon-ce.com>

©HD Construction Equipment. All rights reserved.
2026.01

Certain specifications may differ from actual results based on engineering calculations. Specifications are for comparison purposes only and are subject to change without notice.

The specifications of individual DEVELON equipment may vary due to normal changes in design, manufacturing, operational conditions, and other factors. Some images of DEVELON equipment may show non-standard configurations.

DEVELON

DX60D

Operating Weight: 5,950 kg | Rated Power: 36.4 kW/3,000 rpm | Bucket Capacity: 0.25 m³



DEVELON

Powered by Innovation

DEVELON is powered by 88 years of trusted engineering expertise and proven quality. We transform this legacy into smart products and digital solutions that move the industry forward. Built on trust and driven by innovation, DEVELON remains dedicated to maximizing customer value in the future.

We Are DEVELON

DEVELON represents a renewed and elevated brand identity, built on our core philosophy of sustainable development and a commitment to creating a positive impact. Looking ahead, we will continue to deliver innovative products and solutions that drive progress in today's world.



Optimized Power. Maximized Comfort

The new series inherits the design heritage and is equipped with the DEVELON DW02 turbocharged high-performance engine. DEVELON's customized main pump and main control valve ensure rational power matching with stable and durable performance. Operational comfort has been further optimized, helping customers tackle a wide range of demanding conditions and maximize benefits.



New Hydraulic System

The advanced hydraulic system optimizes the flow output of the main pump according to the load, achieving minimal fuel consumption.

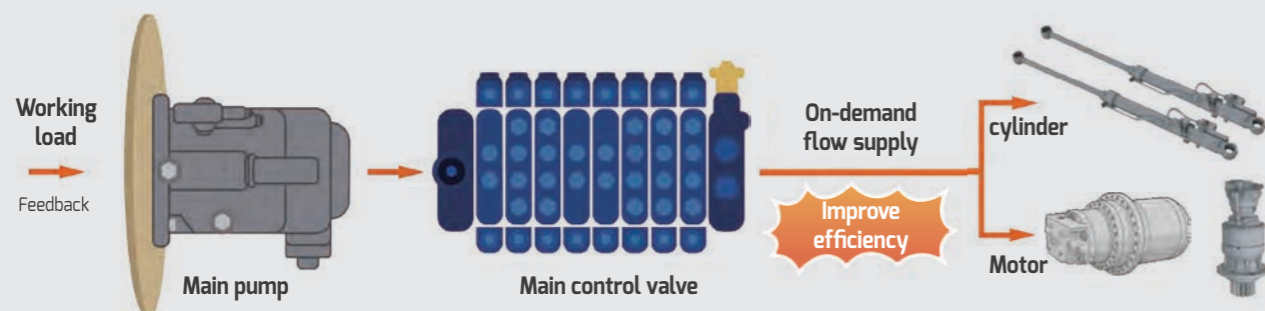

Engine

Manufacturer	DEVELON DW02
Power	36.4 kW/3,000 rpm
Number of Cylinders	4

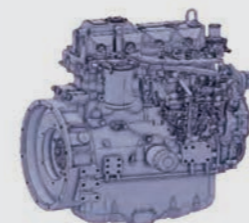

Long and Wide undercarriage

Tumbler distance 2,030mm	Track gauge 1,600mm
Track length 2,550mm	Overall width 2,000mm



Designed to deliver higher performance, durability, and comfort with an in-house engine

- Powerful Performance with Reliable Quality Guarantee

- Powerful performance supported by advanced DEVELON DW02 turbocharged engine, with reliable quality guarantee.
- DEVELON's exclusive custom-designed large-displacement main pump fully utilizes the working capacity of the 0.25 m³ bucket. With stable and reliable performance, the overall efficiency is significantly improved.

- Optimized Performance, Energy Saving, and Ensured Profitability

- The hydraulic system adopts the LS system, which supplies flow on demand. This maximizes energy savings while enabling precise control of multiple movements, thereby improving operational accuracy.
- During combined operations, the boom is given priority, resulting in significantly increased speed and a greatly enhanced operating experience.

- Optimized and Upgraded Structure for Durability and Stability in Harsh Conditions

- Newly upgraded side-mounted boom platform effectively reduces the swing moment of inertia, making it more suitable for hard excavation conditions.
- The widened undercarriage and track shoe design enhance overall operational stability.

- Comfortable Cab Environment, Improved Operating Experience

- A large cab with ample space offers 360-degree all-around visibility.
- The suspension seat effectively filters out operational vibrations, significantly enhancing operator comfort.
- A large display and one-button start enhance convenience.





Optimized shock absorption effect
 Combined with suspension seat
 Reduced operational fatigue

Comfortable and Safe Cab Environment



1. Spacious Cab

Stylish exterior, spacious and bright interior for a more comfortable operation.

2. Air Conditioning System

Comfortable air conditioning system with front and rear outlets ensures a pleasant workspace.

3. Suspension Seat

New adjustable suspension seat (up/down, forward/backward) provides ample cushioning to enhance comfort.

4. Large Display Instrument Panel

Full-color large display provides detailed information and allows for necessary performance settings.

5. Engine Emergency Stop Button

Pressing the stop button cuts off the engine's fuel supply, saving fuel and ensuring personnel safety.

6. Air Conditioning Filter

Easily accessible and cleanable air conditioning filter.

7. Bluetooth Radio

Upgraded features allow Bluetooth or USB connection to mobile phones for listening to music and calling easily.

8. One-Button Start

One-button start for further enhanced convenience.

> Convenient, Fast, and Efficient Maintenance

New convenient maintenance settings provide users with easy and quick operating conditions.



The battery box cover features a new design

The newly designed battery box and storage compartment allow for quick and convenient maintenance with the grease gun securely fixed inside. The protective cover is equipped with a lock cylinder to safeguard the battery and tools.

> Reliable and Convenient Maintenance System

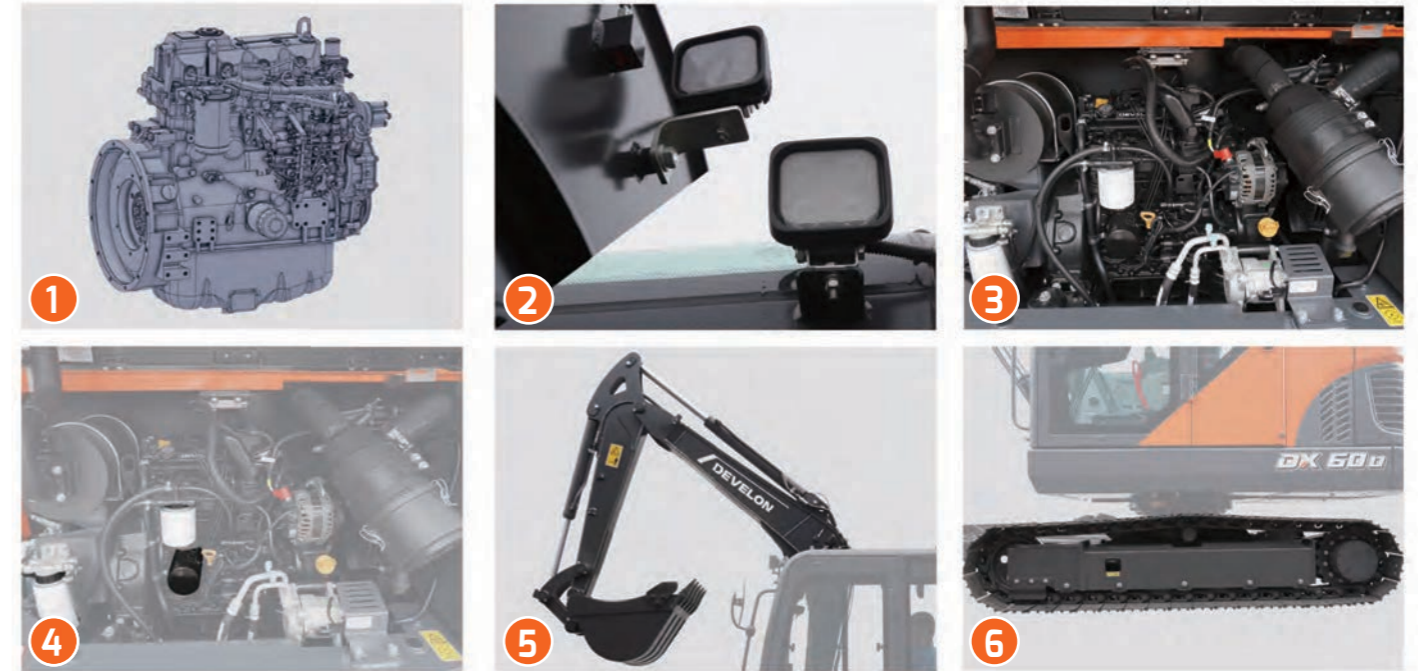

1. Efficient and Durable Engine

DEVELON's 4-cylinder engine has been proven through long-term market application, delivering low fuel consumption, strong power, and excellent durability.

2. LED Work Lights

The all-new high-quality work lights provide a convenient and safe nighttime working environment.

3. Centralized Filter Placement

Opening the engine hood allows easy access to various filters and the water filler, facilitating maintenance.

4. Multi-Stage Fuel Filtration System

The multi-stage fuel filtration system ensures engine durability while reducing harmful emissions.

5. Reinforced Boom and Arm Design

The boom and arm feature reduced welds and an optimized structure to avoid stress concentration. The integrated boom design enhances the structural stability and durability of both the boom and arm.

6. Widened Undercarriage Tracks

Increased track shoe width ensures undercarriage stability during operation in harsh conditions.



Technical Specifications

Model	DX60D		
Max. Digging Reach	A	(mm)	5,946
Max. Ground-Level Digging Reach	B	(mm)	5,811
Max. Digging Depth	C	(mm)	3,812
Max. Loading Height	D	(mm)	4,185
Max. Digging Height	F	(mm)	5,980
Max. Bucket Pin Height	G	(mm)	5,050
Max. Vertical Digging Depth	H	(mm)	3,065
Max. Swing Radius	M	(mm)	2,030
Tail Swing Radius	N	(mm)	1,700
Shipping Height (Boom)	P	(mm)	1,950
Shipping Height (Cabin)	T	(mm)	2,630
Shipping Length	Q	(mm)	5,670
Counterweight Ground Clearance	S	(mm)	700
Track Gauge	X	(mm)	2,030
Track Length (on ground)	Y	(mm)	2,550
Upper Width	U	(mm)	1,990
Lower Width	Z	(mm)	2,000
Track Shoe Width	a	(mm)	400
Overall Track Height	b	(mm)	566
Minimum Ground Clearance	c	(mm)	332

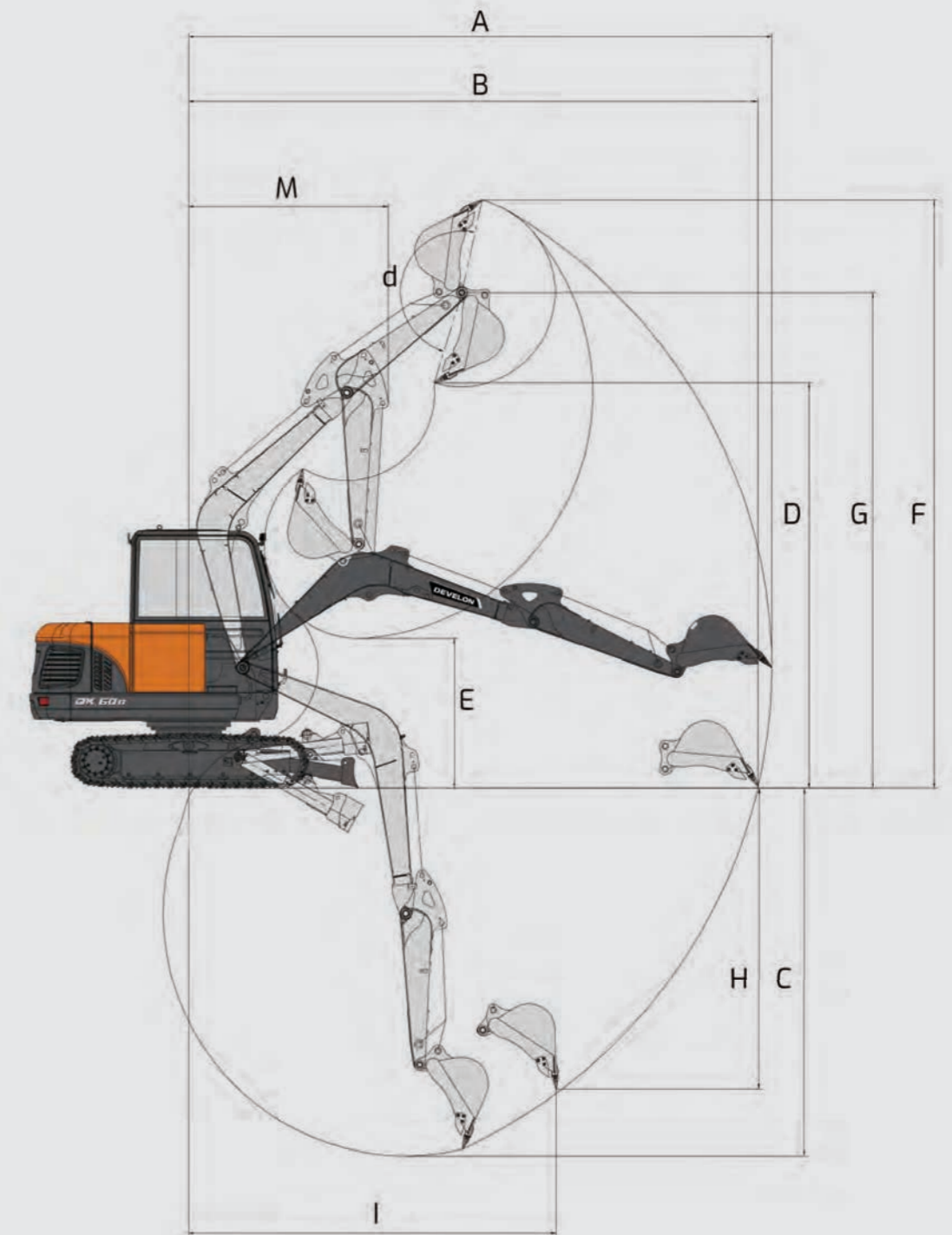
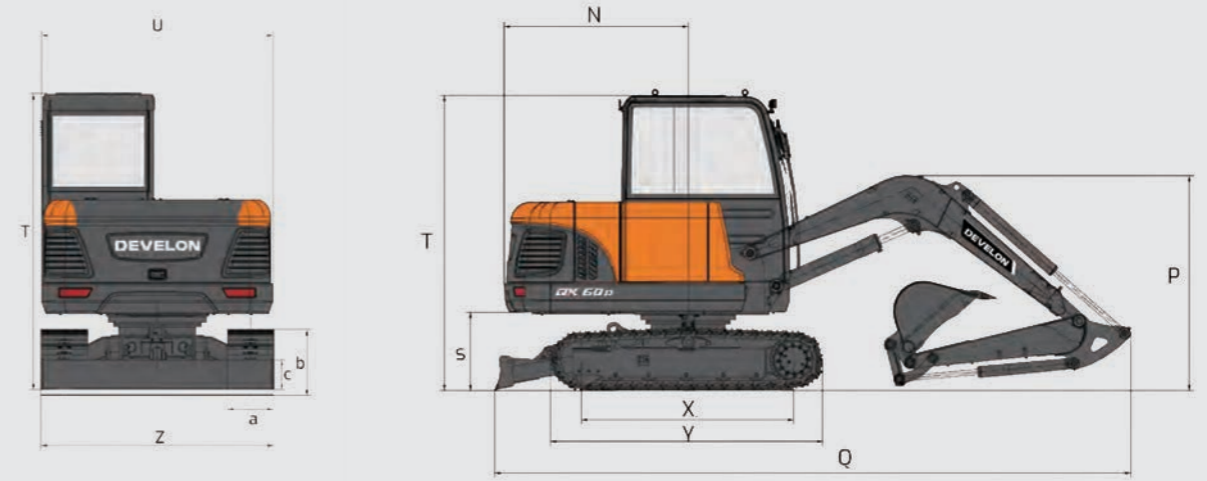

Main Specifications

Engine	
Model	DEVELON DW02
Number of Cylinders	4

Engine	
Cylinder Bore × Piston	φ90×100mm
Rated Power	36.4kW/3,000rpm

Basic Specifications

Boom	3,000mm
Arm	1,550mm
Bucket Capacity	0.25m ³
Track Shoe	400mm
Operating Weight	5,950kg
Swing Speed	11rpm
Travel Speed (High / Low)	4.2/2.5km/hr

Tank Capacity	
Fuel Tank	130L
Engine Oil	9L
Travel Gear Oil	2×2L
Hydraulic Tank	80L

Cylinder	
Boom (Bore × Rod Diameter × Stroke)	110×60×662mm
Arm (Bore × Rod Diameter × Stroke)	90×55×735mm
Bucket (Bore × Rod Diameter × Stroke)	85×50×613mm
Dozer (Bore × Rod Diameter × Stroke)	100×55×152mm

Maximum Digging Force (ISO)	
Bucket	4ton
Arm	2.8ton

GLOBAL PARTS NETWORK

QUALITY-PROVEN MAIN COMPONENTS

Develon provides fast and precise worldwide delivery of genuine Develon parts through its global PDC (parts distribution center) network.



GLOBAL NETWORK

The global network of the GPDC (Global Parts Distribution Center) maximizes its fill rate by making sure that each center is stockpiled with all the critical parts required for businesses in its area. The network also minimizes the time and costs required for parts delivery by positioning PDCs close to major markets around the world. Develon PDCs communicate with customers in their time zone, informing them that they are open for operation, and deliver parts to them as early as possible.

THE GLOBAL PARTS DISTRIBUTION CENTER NETWORK

PDCs had been set up as shown below, including Mother PDC in Ansan, Korea. The ten other PDCs include one in China (Yantai), three in USA (Atlanta, Seattle and Miami), two in Europe (Belgium and the UK), one in the Middle East (Dubai), one in Asia (Indonesia) and one in Brazil (São Paulo).

